



Battery charger for high-speed trains.

The PCS Rail CU 25-110 is a highly efficient battery charger which was specially designed for use in high-speed trains.

The three phase voltage is transferred to the downstream DC/DC converter via a rectifier, which serves to electrically insulate the medium frequencies and regulate the voltage.

The PCS Rail CU 25-110 is located in an underfloor container. Any lost power is released using forced air cooling. The fan required to do this is part of the container. The battery charger starts once it is connected with the input voltage. In addition, software can be used to set a stop/off command. An NTC temperature sensor displays the battery temperature, which is needed to control the output voltage of the battery charger according to the temperature of the battery.

The concept behind the PCS Rail CU 25-110 is based on the use of IPMs (Intelligent Power Modules) or IGBTs. The MOC 100 controller serves many internal functions, controls the power electronics, records events and errors, and enables CAN communication with other sub-systems. The service software is connected using the RS 232 insulated interface.

Properties

- High availability and reliability
- Excellent insulation of critical components
- Easy maintenance and repair
- Windows-based service software
- High efficiency
- Expanded input voltage range
- Uses extremely quiet, electronically commutated DC fans
- Low electromagnetic interference



PCS Rail CU 25-110 underfloor application

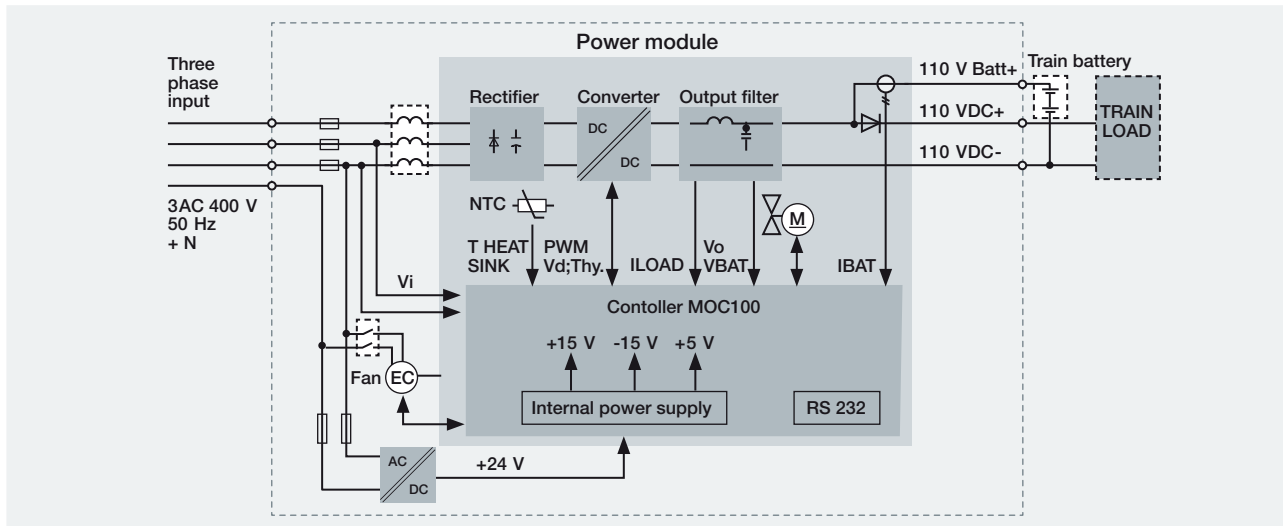

Technical data for PCS Rail CU 25-110:

Technical data

Type	PCS Rail CU 25-110
Mass (kg)	90
Dimensions (L/W/H mm)	880/625/500
Application	Underfloor

Input nominal voltage 3-phase AC	400 V
Frequency of SFIn input voltage	50 Hz
Permitted overvoltage 3-phase AC	500 V
Ambient temperature	-25 °C to +65 °C
Storage temperature	-40 °C to +70 °C
Communication	CAN

DC output

Output power	25 kW
Output voltage	110 V DC
Output voltage range	104 V to 132.4 V DC
Max. output current	210 A
Charge current	78 A
Static ripple	2%

PCS has for decades developed highly reliable power converters and electrical equipment. Take advantage of state-of-the-art solutions plus project management and service.

Main components

Input filter with fuses
Rectifier
DC/DC converter with medium-frequency insulation
Output filter
Decoupling diode
Control interface (power supply and decoupling)
MOC 100 controller
Fan and cooling element

Integrated monitoring functions

Overheat protection for batteries
Battery temperature sensor monitoring
Output short-circuit monitoring
Output overvoltage protection
Input voltage monitoring
Input current monitoring
Monitoring of power supply
Temperature monitoring of control unit
Temperature monitoring of cooling element
Cooling element temperature sensor monitoring
IGBT fault monitoring

Reference projects

Bombardier Zefiro high-speed trains: Ministry of Railways MoR, China Railways (China)
