

1000

PCS Green Line 1000 for LVRT capability: Keeps Your Wind Turbine on the Grid during Voltage Drops.

PCS Green Line 1000 satisfies the requirements of grid operators for the provision of a reactive current during voltage drops in the wind turbine.

Today's power converters need to ensure reliable wind turbine operation even when grids are exposed to strongly fluctuating frequencies or voltages. The international guidelines for grid feed-in and grid compatibility (grid codes) require the delivery of reactive power during the low voltage ride through (LVRT) situation which the Green Line 1000 can fully meet.

Green Line 1000 will keep the system online during brief balanced grid faults of up to 15% or during unbalanced grid faults down to 0% of the grid voltage. During an unbalanced short circuit of two phases in the medium voltage range, Green Line 1000 uses the remaining phase to supply reactive current.

Properties

Flexibly designed for use in a single wind turbine

Easily integrated into existing wind turbines

Customisable due to modular design

Very simple user interface thanks to proprietary service software, and user-friendly interface structure

Supports established field bus systems (CAN, PROFIBUS, ETHERCAT, et al.) while a binary interface is also available

Reactive current increase can be set to a high dynamic

Superior value-for-money ratio

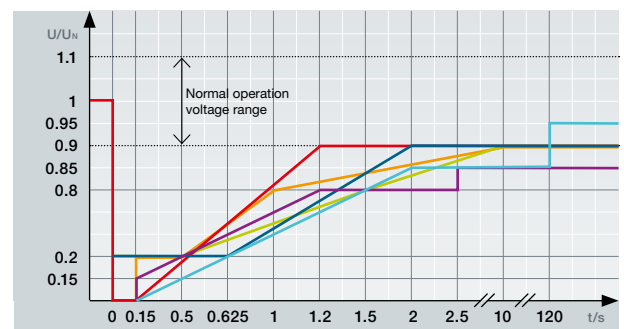

LVRT profiles of national grid codes: ■ Germany ■ Spain ■ Portugal ■ China ■ Great Britain ■ Republic of South Africa

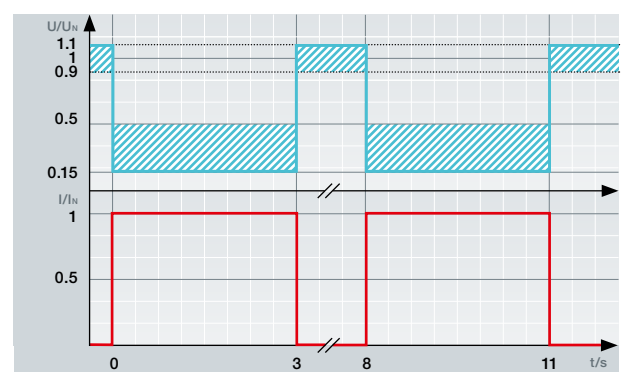

PCS Green Line 1000 performance: ■ Reactive current ■ Grid voltage

Reactive power characteristics can be individually configured through an option to preset the respectively applicable grid code. In addition, the Green Line 1000 uses its intelligent control unit (DCU) to adapt autonomously to the grid requirements.

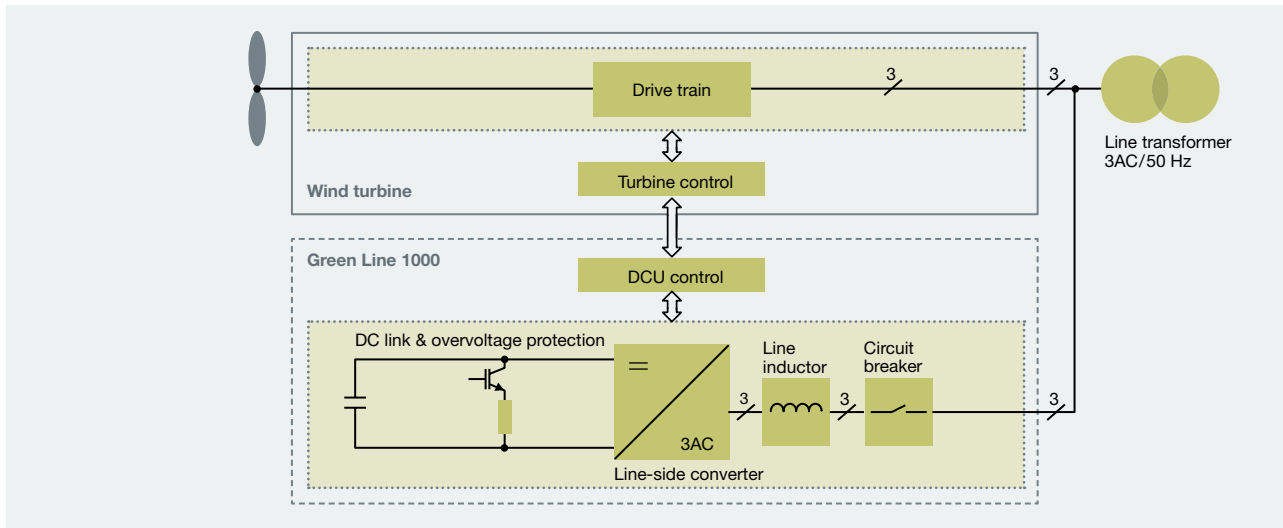

Technical data

PCS Green Line 1000	/2500	/850
Line voltage	3 AC 690 V	
Line frequency	50 Hz/60 Hz	
Maximum current	2500 A	850 A
Maximum duration of current	2 x 3 s	
Cooling	Convection	
Ambient temperature	-20° C to +50° C	
Protection rating	IP 54	
Dimensions L/D/H mm	1400/600/2100	1400/600/1400
Weight approx.	950 kg	750 kg

Options

- Active harmonic compensation for best possible grid quality
- Flicker compensation integrated into the converter – no negative feedback into the grid from the wind turbine
- Reactive power management for the entire system with an adjustable $\cos \phi$
- Zero voltage ride through capability (ZVRT)

PCS Green Line 1000 consists of a pulsed IGBT power converter equipped with voltage link. As long as line-side reference conditions are met, it operates in the stand-by mode. In the event of a line-side voltage drop, it switches into the active mode and supplies a reactive current for a maximum period of six seconds. The Green Line 1000 is available in two performance classes: for large wind turbines up to 2500 A and for smaller turbines up to 850 A. Since it operates for brief periods of time only, it requires no water or forced air cooling. Natural convection fully suffices to cool the system.



PCS Green Line 1000/2500, installed in systems of various OEM with a total output of 130 MW

The power converter is integrated into the wind turbine using a field bus. In order to avoid possible grid resonances, the service software can be used (via the DCU) to set the pulse frequency within the range of 2 kHz to 7 kHz to variable and custom settings. Even stochastic pulse rates may be set in order to avoid undesirable resonances and beat frequencies in scenarios involving the parallel operation of several Green Line 1000 or parallel operation with power converters of a different make.

PCS has developed highly reliable power converters and electrical equipment for decades. Benefit from cutting-edge solutions plus project management and service options.